

## Media Literacy and Young People's Integrity in Political Participation: A Structural Equation Modelling Approach

MOHD SUFIEAN HASSAN  
*Universiti Teknologi MARA, Melaka Branch*

MAIZATUL HAIZAN MAHBOB  
*Universiti Kebangsaan Malaysia*

SITI NURSHAHIDAH SAH ALLAM  
*Universiti Teknologi MARA, Melaka Branch*

FAZURAH MUSTAFFA  
*Universiti Melaka*

NOOR AFZALIZA NAZIRA IBRAHIM  
*Universiti Teknologi MARA, Melaka Branch*

### ABSTRACT

The unethical activities related to weak political participation integrity on social media have influenced negative behaviours among supporters, particularly the young people. Social media transmits information on demonstration activities by enabling the creation, collection, and dissemination of false information or seditious libel, which exposes the country to external attacks and threats. Furthermore, young people's negative political participation activities on social media, such as creating and disseminating false information, making harsh remarks, generating turmoil to acquire popularity or go viral, can potentially lead to cybercrimes. This research identified the impacts of media literacy competencies, namely access, analysis and evaluation, creation, reflection, and action, on political participation integrity among young people. This study distributed a survey to targeted university students in Melaka, Malaysia using the simple random sampling method. The students' participation was purely voluntary. A total of 388 responses were successfully collected. The structural equation authenticated that four competencies significantly influenced the participants' political participation integrity: access, analysis and evaluation, reflection, and action. In addition, young people who have media literacy skills showed a stronger preference to engage in political activities with higher moral conduct. The findings provided valuable insights about young people's political participation integrity on social media in Malaysia.

**Keywords:** *Media literacy competencies, political participation integrity, structural equation modelling, young people, social media.*

### INTRODUCTION

Social media activities with low political participation integrity have influenced negative actions among the young people. According to Malaysian Youth Policy by the Ministry of Youth and Sports Malaysia (2015), young people can be defined as those aged between 15 and 30 and they are deemed to be always aggressive and act radically in participating political activities (Taib & Yaakop, 2017). Young people's negative political participation activities on social media, such as creating and disseminating false information (Berduygina et al., 2019),

making harsh remarks (Samuel-Azran, Yarchi & Wolfsfeld, 2017), generating turmoil to acquire popularity or go viral (Edgerly et al., 2016), can potentially lead to cybercrimes (Marttila et al., 2021). Moreover, young people can utilise social media to circulate seditious libels, thus exposing the country to external attacks and threats (Sushama et al., 2021). Consequently, young people's negative political behaviours on social media directly impact their participation integrity (Weeks et al., 2017).

Notably, young people are commonly associated with acts of aggression and more receptive to technological advancement (Scherman & Rivera, 2021). This group is also an agent of national transformation that guides the country toward its global aspirations (Mohamad et al., 2018). Ensuring the young people are equipped with strong integrity values can generate ethical leaders to drive national transformation in line with religious and cultural values and reduce the inclination for immoral acts in the political system of the country.

In this study, media literacy is predicted to improve the young people's political participation integrity on social media by avoiding unethical behaviours. Media literacy is defined as the ability to comprehend and explain the meaning of information or actions in the media. According to Potter (2018), media literacy is the knowledge of the various media that work in society. In contrast, Wallis and Buckingham (2016) defined media literacy as the skill to comprehend the cultural, economic, and political aspects of media technology, media publishing, and broadcasting information. Additionally, Kahne and Bowyer (2019) described media literacy as a mobile network created to give individuals more control over the media they use to send and receive feedback. Similarly, Heller (2021) indicated that media literacy is the ability to communicate with all media types including printed or electronic, by accessing, researching, and evaluating images, audio, and information.

Furthermore, communication expert Silverblatt (2018) presented a systematic guide to make media literacy a part of a well-informed media culture orientation. He identified five media literacy elements that consumers should acknowledge. Firstly, consumers need to comprehend the impacts of media on individuals and society. In addition, understanding the communication process and the strategies for analysing and discussing information in the media is paramount. Being aware that media content provides insights into the culture and oneself was also emphasised. Overall, consumers require an understanding of the fun and inclination of the media content.

Various factors contribute to more people embracing technology, such as easy-to-use features (Omotayo & Folorunso, 2020), interactive and user-friendly applications, broader social networks (Halpern et al., 2017), and more effective communication processes and social support (Hayes et al., 2016), particularly for the young people. Research on social media usage among the young people proved that interactive applications with multimedia features including audio, video, and mobile graphics make social media more popular than conventional media among Gen-Y. Following that, the new millennium media provide accessibility and direct communication between information owners and target groups, where feedback and questions obtain more efficient responses than traditional media (Weeks et al., 2017).

Essentially, researchers are more likely to study media literacy in the context of qualitative education than quantitatively. This study, however, assesses young people's integrity level, utilising selected new media literacy instruments (Koc & Barut, 2016) which analysed five media literacy competencies: 1) access, 2) analysis and evaluation, 3) creation, 4) reflection, and 5) action. These competencies denote the primary purpose of media literacy

is to improve communication skills and avoid being deceived by media material. Ultimately, this study aimed to enhance the media literacy dimensions by incorporating political participation aspects that are rarely studied in Malaysia.

#### MEDIA LITERACY AND POLITICAL PARTICIPATION

According to Ciurel (2016), media literacy is the ability to critically evaluate and digest media messages and develop and disseminate content via old and new media platforms. Media literacy also facilitates and promotes critical thinking abilities in media messaging to help users avoid or reduce content risk, personal information risk, and behavioural risk. Technological media advancement has resulted in a wide range of data and information, requiring data-rich media literacy abilities to process complicated media landscapes. The internet has altered the way people communicate and receive information. Therefore, media literacy is crucial to ensure users can critically assess the information they received (Kim, 2019).

Notably, individuals with digital literacy can live, learn, work, and participate as digital citizens. The Australian Communication Media Authority (ACMA) defined digital media literacy as understanding and application of information in various formats from numerous sources. Skills, comprehension, and knowledge enable safe and effective media use and the ability to communicate in many situations through using, understanding, and creating communication materials (Australian Communication Media Authority, 2009).

Access and retrieval, analysis and evaluation, communication, creation, reflection, and action are critical media literacy abilities in the digital era (Hobbs, 2010; Kahne et al., 2012; Lin et al., 2013). Hobbs (2017) defined media literacy as the ability to use, analyse, evaluate, and create information online through digital media. Presently, individuals need advanced communication configuration and problem-solving abilities spanning five digital media competencies: access, analysis and evaluation, creation, reflection, and action.

Additionally, to become well-versed in digital media literacy, individuals must equip themselves with the skills to comprehend, analyse, and evaluate online information and news (Bowyer & Kahne, 2020) and communication skills (the ability to locate, save, distribute, produce, and evaluate data). Furthermore, creative activity, critical thinking, risk awareness, internet chances, the ability to innovatively produce content using digital media tools (Gotlieb & Cheema, 2017) or discuss political issues (Hodgin, 2019) are also important. Solid technical and critical thinking skills allow users to adequately evaluate and analyse media content to obtain correct and valid information (Hobbs, 2017). Despite the efficiency of using new media to obtain information, it can also lead to abuse and cybercrime. According to Tan Sri Mohamad Fuzi Harun, the Inspector-General of Police in Malaysia, digital technology aided by unrestricted access to social media has contributed to a broad spectrum of commercial crime trends, particularly cybercrimes (Shaari & Kamaluddin, 2019). These cybercrimes include slandering the leaders of the country, weakening the power of the monarchy and the federal constitution, and consequently leading to moral collapse, political instability, and the loss of social and national sovereignty.

Moreover, consumers, particularly young activists (Lee & Ting, 2015), are content providers in the new media (Middaugh, 2019). Digital media interactions act as a knowledge source (Zoizner, 2021) and an educational tool for the young people. Many individuals can now create their own games, music, news, and videos. Previously, these functions were solely available to media professionals. In addition, regular people can make and share materials

from start to finish as digital publishing tools are inexpensive. Ultimately, media literacy is digital production abilities that include creative and critical skills in accessing and generating media content (Silverblatt, 2018) and not merely a matter of interpretation or contextual knowledge.

New media literacy is a social and cultural skill learned online and is based on core literacy abilities, such as reading and writing, research skills, and critical media analysis abilities (Cappello, 2017). Martens and Hobbs (2015) stated that critical reading and writing skills are imperative in the digital media era to improve the young people's ability to evaluate information. These skills are necessary to provide effective digital media literacy programmes and ongoing learning opportunities for civic participation (Mihailidis, 2019). These digital media literacy abilities are required for full engagement in social and political activities as engaged citizens in a democratic society (Hodgin, 2019).

Besides, individual expressions have given way to community involvement (Middaugh, 2019) and public participation in new media literacy allows people to be aware about media and its impact (Tugtekin & Koc, 2020), enables society to voice and share their views, and empowers people to express and share their opinions through all forms of digital media (Gong & Verboord, 2020). Presently, digital media technology has become an integral part of civic and political life, particularly among young people (Middaugh, 2019).

The young people can benefit from media literacy as they have direct experiences through online courses, discussions, publications, and collective action (Powers et al., 2016). Media literacy has become a metric for assessing the young people's abilities to engage in civic engagement and political participation in support of democratic institutions and practices in Malaysia. As the primary source of information for the people and the government, there is a strong link between media communication and politics. Unfortunately, restricting undesirable outcomes of new media usage is challenging as users can speak freely and publicly.

Generally, authorities have difficulties eradicating unethical activities as Malaysia has around 30 million internet users who can register for multiple social media accounts under different names (Faris, 2022). When misconduct occurs, authorities must dedicate a significant amount of time locating the person who made the initial statement or committed the act. Overall, providing critical education and skills to promote integration and awareness while also acting as a deterrent to unethical actions and activities in the community is vital. New media literacy skills are an excellent way to nurture and teach children from a young age to act ethically while using social media (Fawkes, 2020). Media literacy skills must be included in primary and secondary education to nurture digital citizens with complete integrity and moral principles.

### *Access*

The competence in accessing media content is vital for the young people to guide their actions with integrity. Media literacy and political participation steered a new direction in determining aspects of the access competence (Ashley & Maksl, 2017; Middaugh, 2019). According to Kim and Johnson (2012), this competency enabled access to political blogs. Blog users with high political participation and inclination were attracted to political blogs as political information could be shared freely.

Apart from the education level and internet use frequency, news content significantly lowered political participation among the young people. In line with that, various platforms were analysed to measure individuals' media access skills. Among them were television and radio (Ojebuyi & Salawu, 2015), Internet (Bober et al., 2010), social media (Loader et al., 2014), and smartphones (Koo et al., 2014). Resultantly, the young people utilised these platforms to access current political information.

In shaping political interest via knowledge, political scientists and media scholars believe that high media literacy rates contribute to users having access to quality information resources (Ptaszek, 2018). Social media offers an interactive platform that enables communication with those who have similar interests. A more interactive and open political discussion space makes this media accessible to the young people when engaging in online politics (Kiyohara et al., 2018). Therefore, the young people must develop their political inclinations and knowledge using strong media literacy competencies (Hodgin, 2019). Thus, increasing political participation integrity. Nonetheless, social media access does not promise the young people's political involvement (Casero-Ripollés, 2017).

Additionally, Ali and Mohd Safar (2011) studied access to online newspapers and general elections. Online media was reported to offer a more interactive platform for everyone to access and use. Individuals can conveniently obtain political information with the help of computers and internet connections (Bakker & de Vreese, 2011). The skill to access media content certainly contributes to the political participation integrity among the young people as it eliminates the harmful effects of the media. This can strengthen the political integrity of participation among young people in social media.

**H1:** Access skills significantly influence political participation integrity.

### *Analysis and Evaluation*

Diverse media content is easily accessible. Thus, robust analysis and evaluation skills are crucial. Hobbs (2010) defined analysis and evaluation as the ability to think critically, convey messages, be creative, and engage in ethical behaviours. In addition, analysis and evaluation skills include the abilities to research and evaluate from numerous information sources (Lewis & Jhally, 1998), understand information and think critically about information sources (Potter, 2018), and compare them with other sources (Siti Nurshahidah et al., 2020, Mohd Sufiean et al., 2020).

Furthermore, analysis and evaluation skills are the main channels of media literacy (Potter, 2018). Many academics in the psychology, sociology, and socio-politics domains stated that the primary purpose of media literacy is to assess media use and interpret media content (Eristi & Erdem, 2017). The ability to perform analysis and evaluation is relevant to the young people as it is used daily. Even with its features that suit the young people, it further enhances access to information. This, in turn, leads to the need for analysis and evaluation skills. Notably, a person with strong media and digital literacy will respect others' rights. In addition, analysis and evaluation skills enable the young people to seek out political information and ensure that it is authentic, correct, ethical, and moral (Hobbs, 2010). These skills can also encourage the young people to speak freely and with integrity (Aufderheide, 1992; Hobbs, 2010).

Ultimately, integrity is created by comparing political data quality. Positive political information significantly impacts civic activities in a society (Givskov & Trenz, 2014) and strengthens national democracy (Chang, 2017) and beliefs in the political system. Previous studies identified that political information, particularly news on social media, contained more provocative information than traditional media, such as television, radio, and newspapers. Exposure to greater provocative content greatly influences political participation integrity (Lailiyah et al., 2018). Therefore, the following hypothesis was proposed:

**H2:** Analysis and evaluation skills significantly influence political participation integrity.

### *Creation*

According to Kahne et al. (2012), creation is the ability to creatively create and compose information to share with digital citizens. Individuals with this competency can quickly and efficiently construct and produce media content, such as video clips, photos, and text. This competency allows the young people to express their feelings and share knowledge by creating and sharing political media content in various forms. This is in line with Hobbs (2010) which denoted the creative aspect as creating media materials in various forms and formats.

In addition, the Ministry of Education in Finland underlined the importance of media materials creation as they are more interactive and allow new perspectives and meanings to be developed (European Commission, 2010). Resultantly, a thorough understanding of media content generation enables the young people to be more efficient, specifically when it involves political participation. Creating digital information can reduce costs for users as they can quickly create, share, and distribute media content through social media channels. Casero-Ripollés (2017) also indicated that digital information gives users more freedom to produce their materials. Previously, only the elite could create media content. In contrast, anyone can create and share media content with the availability of social media. This competency facilitates more political engagement in cyberspace and strengthens democracy.

Efforts to educate young people on the ability to create media information have been started in many countries. But the ability to produce political content needs to be based on the efficacy of political knowledge. The importance of knowledge is an important determinant of the creation of political content for young people. This idea is in line with the study of Kaid et al. (2007) in which the political knowledge of young people has a significant relationship in ensuring the level of political participation of this generation. The confidence of young people to express political knowledge through the creation of political content on social media directly affects the high level of political participation of young people (Jenkin, 2016; Kahne & Bowyer, 2018). Besides that, the level of education (Berinsky & Lenz, 2011), the level of political inclination based on the requirements of the study syllabus (Arsenijević & Andevski, 2016) and time commitment to create and generate political information to share with netizens (Östman, 2012) are also factors of young people create and share political content. Therefore, the following hypothesis was proposed:

**H3:** Creation skills significantly influence political participation integrity.

### *Reflection*

Reflection skills help individuals make moral and ethical decisions while creating media content and materials (Nupairoj, 2016). This statement is aligned with Potter (2018) who stated that one must have a social responsibility and internal integrity that can be used to benefit oneself and others. Additionally, Hobbs (2010) defined media literacy interpretation as combining skills, such as emotional reasoning and social skills in technology use. This competency includes the ability to respond ethically (Koc & Barut, 2016).

Essentially, media literacy involves acceptance, culture, emotional intelligence, and enthusiasm (Potter, 2018). There are distinct differences in how individuals in different countries interact. A non-response can be influenced by the media information sought and received. Following that, content released on entertainment social media sites does not have the same impact as the old political social media (Keller & Kleinen-von Königslöw, 2018). This is due to the need to understand and assess the potential risks and dangers of such media messages. Therefore, users must understand how differences in values and life experiences could influence the use and interpretation of media messages.

Life experiences affect a person's vision and understanding. One can enhance their ability to acquire information in a broader perspective and more critically by contemplating their actions and developing media literacy competencies. According to Hobbs (2017), an individual who understands the concepts of privacy and public and honours legal rights and obligations must be equipped with a reflection element (copyright, intellectual freedom). It is crucial to acknowledge that communication possesses the power to maintain status quo, dominate government, and change the world.

Consequently, reflection skills lead to critical media use by evaluating the consequences of responses. Being proficient with this competency helps individual's problem-solve and express their opinions and rights under ethical standards and social and legal obligations. In addition, it aids the understanding of how a person's personal choices influence society and contribute to the actions of a particular community. Therefore, the following hypothesis was proposed:

**H4:** Reflection skills significantly influence political participation integrity.

### *Action*

Individuals with media literacy use the media to exchange information, discuss ideas, and get news from other sources. Media users were shaped by their understanding and awareness of media literacy skills. Resultantly, they become more conscious of their behaviours and alert to moral conduct and civic engagement (Suwana, 2021). Access to reliable media significantly increases political knowledge and encourages individuals to engage in political activities ethically (Shiratuddin et al., 2016).

In contrast, access to social media could also contribute to activities of weak political participation integrity, such as participating in street demonstration activities, provocation, and protesting (Syahputra, 2019). Ultimately, the convenience of social media is often used for political expression. Nonetheless, the young people's political expressions on social media containing controversial, provocative issues, or hate speech related to politics and religious beliefs positively correlated to low political participation integrity (Östman, 2012; Syahputra, 2019).

A study conducted by Willnat et al. (2013) in Malaysia reported that social media use significantly affected political participation among the young people. The use of social media is reported to greatly influence online political participation among young people. Therefore, providing guidelines and ethics of media use is critical (Aufderheide, 1992) as media literacy can strengthen the political participation integrity among the young people (Siti Nurshahidah et al., 2020).

Furthermore, media literacy education encourages the young people to act with integrity and morals (Middaugh, 2018) and combat political apathy and cynicism (Vraga & Tully, 2019). The young people equipped with these skills would be more rational and critical in choosing a credible platform to obtain political information (Bowyer & Kahne, 2020). They can also generate new perspectives, thus helping them become more ethical active media users.

Social media offers more interactive features than traditional media, such as radio, television, and newspapers (Mohd Sufiean et al., 2019). These features allow the young people to engage in online political activities including conversations, discussions, signing petitions online, sharing information, and liking updates from politicians' accounts or other social media users. Media access and analysis skills influence engagement prudently. These abilities also impact the young people's quality of life, develop social norms, and strengthen political beliefs (Ashley & Maksl, 2017). Therefore, the following hypothesis was proposed:

**H5:** Action skills significantly influence political participation integrity.

The proposed research model is presented in Figure 1.

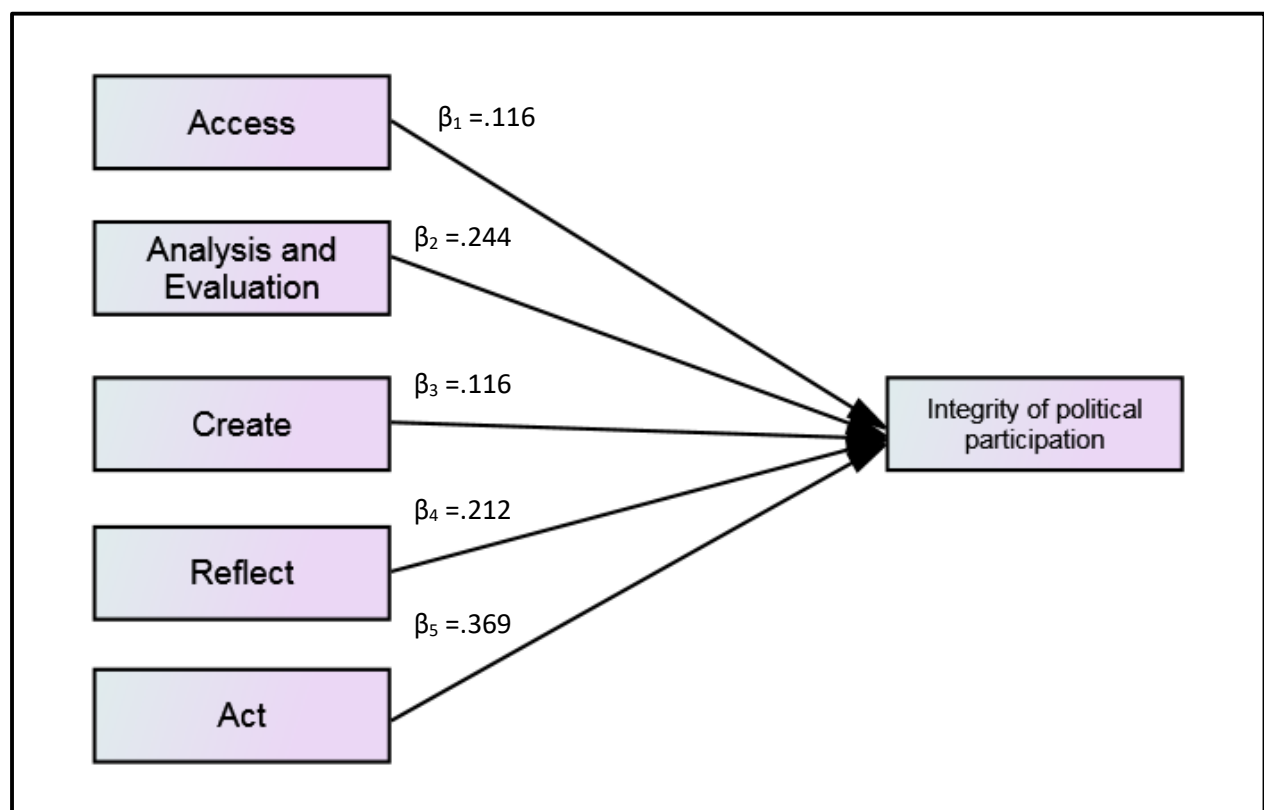

Figure 1: Research model



## METHODOLOGY

The students selected for this study were from four universities located in Melaka, Malaysia: Universiti Teknologi MARA Melaka (UiTM), Universiti Teknikal Malaysia (UTeM), Multimedia Universiti Melaka (MMU), and Kolej Universiti Islam Melaka (KUIM). The target sample was selected using the simple random sampling method. A questionnaire containing two parts was used as an instrument for this study. Part A consists of general information regarding demographic variables such as gender, age, status, race, education and social media use. Part B contains a New Media Literacy Scale (NMLS) adapted by Koc and Barut (2016) which contains five aspects namely Access, Analysis and Evaluation, Creation, Reflection and Action. Pilot test for this study shows that Cronbach Alpha (reliability) of Access, Analysis and Evaluation, Creation, Reflection and Action exceed the acceptable threshold level of 0.7. A survey method was used to collect data from students between the ages of 21 and 40. A total of 400 questionnaires were distributed online, and 388 respondents answered. Structural Equation Modelling (SEM) approaches were employed to test the study model using AMOS 21.0 computer software. The SEM thoroughly tested the links between observable and latent variables of the hypotheses (Hoyle, 1995). The statistical method combined path analysis, factor analysis, and linear regression into a theoretical causal model for analysis of latent constructs and measurable variables (Anderson & Gerbing, 1988).

Table 1: Internal consistency

Variable	Cronbach Alpha
Access	0.92
Analysis and Evaluation	0.92
Creation	0.89
Reflection	0.91
Action	0.89

## FINDINGS AND DISCUSSIONS

The survey received a 97% response rate. Out of 388 respondents, 42.5% were females and 57.5% were males. In addition, 54.9% of the respondents were between 21 and 23 years old. Over 87% of the respondents were single. Most respondents had received higher education: 2.6% fulfilled STPM, 3.6% completed Matriculation, 2.6% obtained Pre-Diplomas, 59.8% earned Diplomas, and 32% finished Bachelor's degrees. Moreover, 49.2% of respondents utilised social media more than ten times daily, while 29.6% updated social media accounts every 1-30 minutes. The respondents' demographic profiles are presented in Table 2.

Table 2: Demographic profiles of the respondents

Profile	Frequency	Percentage (%)
<b>Gender</b>		
Male	165	42.5
Female	223	57.5
<b>Age</b>		
18-20	37	9.5
21-23	213	54.9
24-26	88	22.7
27-29	37	9.5
30-40	13	3.4

<b>Marital status</b>		
Single	338	87.1
Married	38	9.8
Other	12	3.1
<b>Race</b>		
Malay	286	73.7
Chinese	66	17.0
Indian	19	4.9
Other	17	4.4
<b>Religion</b>		
Islam	290	74.7
Christian	39	10.1
Buddha	36	9.3
Hindu	17	4.4
Other	6	1.5
<b>Education level</b>		
STPM	10	2.6
Matriculation	14	3.6
Pre-Diploma	10	2.6
Diploma	232	59.8
Degree	124	32.0
<b>Higher Education Institution</b>		
UiTM	136	35.1
UTeM	99	25.5
MMU	100	25.8
KUIM	53	13.7
<b>Frequency of using social media in a day?</b>		
1-2 times	24	6.2
3-5 times	80	20.6
6-10 times	93	24.0
> 10 times	191	49.2
<b>The time used to update social media accounts?</b>		
1-30 minutes	115	29.6
31 minutes-1 hour	98	25.3
1 hour-2 hours	85	21.9
> 3 hours	90	23.2

### *Reliability Analysis*

The convergent validity, discriminant validity, and reliability of the multiple-item scales were examined based on the Confirmatory Factor Analysis (CFA) results (Fornell & Larcker, 1981). Composite reliability (CR) which measures the extent to which items are free of random error were utilised to examine reliability. In contrast, convergent validity was determined using factor loadings and average variances (AVE). Previous research indicated that convergent validity necessitates a factor loading of more than 0.50 and an AVE greater than 0.50.

The composite reliability values were found to be varied from 0.866 to 0.925, which was higher than the proposed cut-off of 0.70 (Nunnally & Bernstein, 1994). All items demonstrated statistically significant loadings of greater than 0.50. The factor loadings and reliability details are presented in Table 3.

Table 3: Factor loadings and reliability

Construct / Measurement item	Standardised Loading	CR	AVE
<b>Access</b>		0.866	0.620
AS1	0.961		
AS2	0.947		
AS3	0.535		
AS4	0.824		
<b>Analysis and Evaluation</b>		0.925	0.639
AE1	0.929		
AE2	0.974		
AE3	0.963		
AE4	0.819		
AE5	0.832		
AE6	0.821		
<b>Creation</b>		0.902	0.647
CR1	0.906		
CR2	0.957		
CR3	0.716		
CR4	0.864		
CR5	0.827		
<b>Reflection</b>		0.887	0.616
RF1	0.927		
RF2	0.649		
RF3	0.974		
RF4	0.978		
RF5	0.964		
<b>Action</b>		0.899	0.690
AC1	0.945		
AC2	0.978		
AC3	0.898		
AC4	0.846		

The AVE was used to measure discriminant validity (Fornell & Larcker, 1981). The AVE values for all constructs were more than 0.5. All square roots of the AVE values were greater than off-diagonal correlation elements, denoting that discriminant validity was achieved. The correlation matrix and roots of the AVEs are presented in Table 4.

Table 4: Correlation matrix and roots of the AVEs (presented as diagonal elements)

	1	2	3	4	5	6
(1) Access	0.786					
(2) Analysis and Evaluation	0.634	0.789				
(3) Creation	0.439	0.635	0.804			
(4) Reflection	0.304	0.545	0.791	0.795		
(5) Action	0.287	0.531	0.724	0.765	0.830	
(6) Political Participation Integrity	0.492	0.703	0.757	0.758	0.803	0.859
Mean	4.907	4.663	4.253	4.089	3.962	4.322
Std. Deviation	1.165	1.261	1.397	1.452	1.477	1.065

\*\* Correlation is significant at the 0.01 level (2-tailed)

### Path Analysis

The SEM model calculated the path coefficients which reflected the strength of the correlations between the dependent and independent variables. Alternatively, the R-square value denoted how much variation is explained by the independent variables. The route coefficients in the SEM model indicated the standardised regression coefficients.

The structural model depicting the hypothesised linear and causal relationships among the variables was examined using data from the validated measurements. The squared multiple correlations for the structural equations index implied the independent variables explained 78% variation in the dependent variable. Figure 2 illustrates the research findings, whereas Table 5 demonstrates the causal routes properties (standardised path coefficients ( $\beta$ ), standard error, p-value, and hypotheses outcomes).

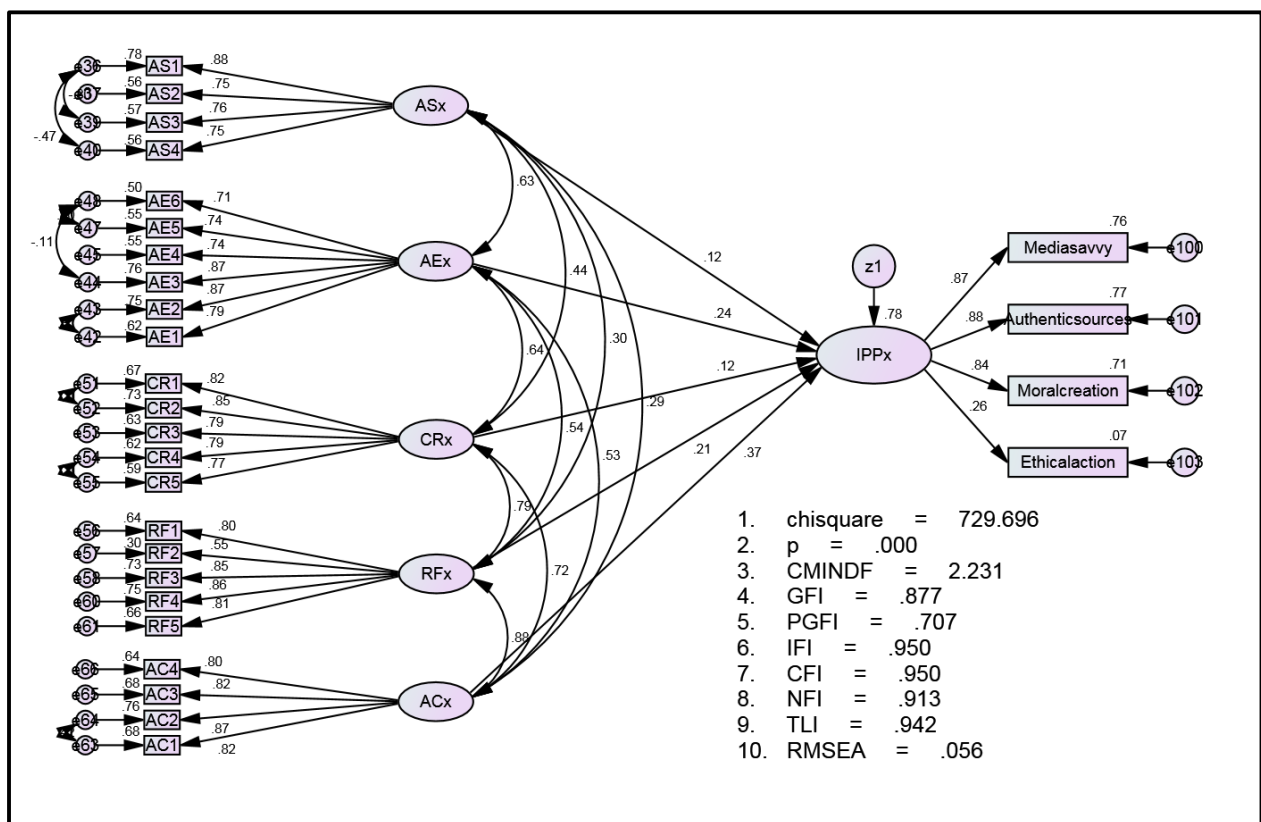

Figure 2: Estimated research model

### Political Participation Integrity

Media access skills significantly influenced political participation integrity among the young people at 0.05 level ( $\beta_1 = 0.116$ ), as presented in Table 5 and Figure 2. Thus, H1 was supported, proving that this competency would help the young people avoid deviant behaviours and increase their political participation integrity. Furthermore, analysis and evaluation skills positively influenced the political participation integrity among the young people ( $p = 0.05$ ,  $\beta_2 = 0.244$ ), which supported H2. Utilising this competency to evaluate media content, particularly political information, would nurture the young people's strong integrity in political participation.

In contrast, H3 was not supported as the impact of creation ability on political participation integrity was insignificant at 0.05 level ( $\beta_3 = 0.116$ ). Consequently, the skills to create media content reflected no positive effect on political participation integrity. The young people with high education levels were also not more strongly affected by media literacy-related predictors. It shows that young people are not motivated to talk about or produce political content. This finding is supported by Kligler-Vilenchik (2022), who found that there are several reasons why young people do not create political material. One of them is because they feel that politics does not affect their lives much, which is one of the reasons mentioned. In addition, despite having an interest in politics, it is restricted to in-person interactions only. Alternately, H4 was supported as reflection skills positively influenced political participation integrity at 0.05 level ( $\beta_4 = 0.212$ ). The young people with a solid reflection skill can provide good and ethical political reflections as they know how to voice out their opinions through the proper channels.

In addition, the ability to act positively influenced political participation integrity at 0.05 level ( $\beta_5 = 0.369$ ), thus proving H5. This competency enhances the young people's political participation integrity by empowering the young people to engage in political activities and discourses in a reasonable manner.

Table 5: Hypotheses test results

	Path			$\beta$	S.E.	p	Result
H1	IPP	<---	ASx	.116	.363	.007	Supported
H2	IPP	<---	AEx	.244	.446	***	Supported
H3	IPP	<---	CRx	.116	.577	.095	Not Supported
H4	IPP	<---	RFx	.212	1.206	.048	Supported
H5	IPP	<---	ACx	.369	.688	***	Supported

Notes: Path = Relationship between independent variable on dependent variable;  $\beta$  = Standardised regression coefficient; S.E. = Standard error; p = Level of significance

#### IMPLICATIONS AND CONCLUSION

Empirical research was conducted to determine the political participation integrity predictors among the young people in Malaysia. Resultantly, the young people's political participation integrity was explained by four media literacy competencies: access, analysis and evaluation, reflection, and action. This finding supported earlier results by Aufderheide (1992), van Deursen and van Dijk (2008), Hobbs (2010), Nupairoj (2016), and Koc and Barut (2016), depicting media literacy enhancements are required to assist users in avoiding content risk, personal information risk, and behavioural risk.

The implications for governments, agencies, and system developers are also discussed. The findings provided valuable evidence-based recommendations for developing practice and policymaking that are focused on the young people's political participation. In maintaining and strengthening political participation integrity among the young people, policymakers should concentrate on improving access, analysis and evaluation, reflection, and action competencies in their development strategies for the National Young People Development Policy of Malaysia.

Besides, government agencies must establish implementation methods that highlight the political participation integrity and media literacy competencies to promote favourable attitudes towards political participation. Therefore, an effective and continuous plan to teach and educate the young people on solidifying their political participation integrity is required.

Moreover, government authorities managing social media platforms must recognise that the competence to act is crucial in determining the political involvement integrity among the young people on social media.

Conclusively, the government must provide a user-friendly interface, strengthen integrity systems for political participation, and build a proper information system flow consistent with political participation integrity. In addition, politicians must establish a country with constructive commentaries and information that encourage citizens, particularly the young people, to behave morally by utilising the appropriate channels to express their opinions.

#### FUTURE RESEARCH

The five variables included in this research might not adequately account for all factors impacting the young people's political participation integrity. Therefore, future research should explore additional competencies contributing to the young people's political participation integrity. Moreover, future studies should increase the sample size and ensure their respondents are demographically diverse. Additional methodologies, such as a longitudinal study, could be an excellent option for analysing the variables impacting the young people's political participation integrity.

#### ACKNOWLEDGEMENT

The authors would like to thank the Ministry of Higher Education Malaysia for the funding received under the Fundamental Research Grant Scheme 2020 (FRGS/1/2020/SS0/KUIM/03/1) to support this study.

#### BIODATA

*Mohd Sufiean Hassan* is a senior lecturer and researcher at the Faculty of Communication and Media Studies, Universiti Teknologi MARA, Melaka Branch. Email: mohdsufiean@uitm.edu.my

*Maizatul Haizan Mahbob* is a senior lecturer and researcher at Faculty of Social Sciences and Humanities, Universiti Kebangsaan Malaysia. Email: maiz@ukm.edu.my

*Siti Nurshahidah Sah Allam* is a senior lecturer and researcher at the Faculty of Communication and Media Studies, Universiti Teknologi MARA, Melaka Branch. Email: shahidah321@uitm.edu.my

*Fazurah Mustaffa* is a senior lecturer and researcher at Universiti Melaka. Email: fazurah@kuim.edu.my

*Noor Afzaliza Nazira Ibrahim* is a senior lecturer and researcher at the Faculty of Communication and Media Studies, Universiti Teknologi MARA, Melaka Branch. Email: afzaliza@uitm.edu.my

## REFERENCES

- Ali, S., & Mohd Safar, H. (2011). New media and democracy: The changing political landscape in Malaysia. *Akademika*, 81(1), 15–21.
- Anderson, J. C. J., & Gerbing, D. D. W. D. D. W. (1988). Structural equation modeling in practice: A review and recommended two-step approach. *Psychological Bulletin*, 103(3), 411–423. <https://doi.org/10.1037/0033-2909.103.3.411>
- Arsenijević, J., & Andevski, M. (2016). New media literacy within the context of socio-demographic characteristics. *Procedia Technology*, 22, 1142–1151. <https://doi.org/10.1016/j.protcy.2016.01.161>
- Ashley, S., & Maksl, A. (2017). News media literacy and political engagement: What's the connection? *Journal of Media Literacy Education*, 9(1), 79–98.
- Aufderheide, P. (1992). *Media literacy: A report of the national leadership conference on media literacy*. Washington, DC: Aspen Institute.
- Australian Communication Media Authority. (2009). Digital media literacy in Australia: Key indicators and research sources.
- Bakker, T. P., & de Vreese, C. H. (2011). Good news for the future? Young people, Internet use, and political participation. *Communication Research*, 38(4), 451–470. <https://doi.org/10.1177/0093650210381738>
- Berduygina, O. N., Vladimirova, T. N., & Chernyaeva, E. V. (2019). Trends in the spread of fake news in the mass media. *Media Watch*, 10(1), 122-132.
- Berinsky, A. J., & Lenz, G. S. (2011). Education and political participation: Exploring the causal link. *Political Behavior*, 33, 357–373. <https://doi.org/10.1007/s11109-010-9134-9>
- Bober, M., Livingstone, S., & Helsper, E. (2010). *Internet literacy among children and young people: Findings from the UK children go online project* [Monograph (Report)]. LSE Research Online. <http://eprints.lse.ac.uk/397/>
- Bowyer, B., & Kahne, J. (2020). The digital dimensions of civic education: Assessing the effects of learning opportunities. *Journal of Applied Developmental Psychology*, 69, 101162.
- Cappello, G. (2017). Literacy, media literacy and social change. Where do we go from now? *Italian Journal of Sociology of Education*, 9(1), 31-44.
- Casero-Ripollés, A. (2017). Producing political content for web 2.0: Empowering citizens and vulnerable populations. *Profesional De La información*, 26(1), 13–19. <https://doi.org/10.3145/epi.2017.ene.02>
- Chang, W.-C. (2017). Media use, democratic values, and political participation: Rmpirical evidence from Taiwan. *Japanese Journal of Political Science*, 18(3), 385–406. <https://doi.org/10.1017/S1468109917000081>
- Ciurel, D. (2016). Media literacy. *Professional Communication and Translation Studies*, 9, 13-20. <https://www.ceeol.com/search/journal-detail?id=621>
- Egerly, S., Thorson, K., Bighash, L., & Hannah, M. (2016). Posting about politics: Media as resources for political expression on Facebook. *Journal of Information Technology & Politics*, 13(2), 108-125.
- Eristi, B., & Erdem, C. (2017). Development of a media literacy skills scale. *Contemporary Educational Technology*, 8(3), 249–267.
- European Commission. (2014, July 21). *Study on the current trends and approaches to media literacy in Europe*. EU Publication. <https://op.europa.eu/en/publication-detail/-/publication/4815621e-3057-4be5-96a4-cfd013d879a5/language-en/format-PDF/source-77154575>

- Faris Fuad. (2022, Mac 30). Malaysia perlu bantuan agensi luar tangani jenayah siber. *Berita Harian*. <https://www.bharian.com.my/berita/nasional/2022/03/940362/malaysia-perlu-bantuan-agensi-luar-tangani-jenayah-siber>
- Fawkes, L. (2022). The powers of media literacy education. *Early Years Educator*, 23(14), 23-25.
- Fornell, C., & Larcker, D. F. (1981). Evaluating structural equation models with unobservable variables and measurement error. *Journal of Marketing Research*, 18(1), 39-50. <https://doi.org/10.2307/3151312>
- Givskov, C., & Trenz, H.-J. (2014). Civic engagement through mainstream online newspapers: Possibilities and shortcomings. *MedieKultur: Journal of Media and Communication Research*, 30(56), 44-60. <https://doi.org/10.7146/mediekultur.v30i56.16969>
- Gong, Q., & Verboord, M. (2020). Social media use and health information seeking and sharing among young Chinese adults. *The Journal of Social Media in Society*, 9(1), 85-108.
- Gotlieb, M. R., & Cheema, S. E. (2017). From consumer to producer: Motivations, Internet use, and political consumerism. *Information Communication and Society*, 20(4), 570-586. <https://doi.org/10.1080/1369118X.2016.1202301>
- Halpern, D., Valenzuela, S., & Katz, J. E. (2017). We face, I tweet: How different social media influence political participation through collective and internal efficacy. *Journal of Computer-Mediated Communication*, 22(6), 320-336. <https://doi.org/gckds9>
- Hayes, R. A., Carr, C. T., & Wohn, D. Y. (2016). It's the audience: Differences in social support across social media. *Social Media+ Society*, 2(4), 2056305116678894.
- Heller, R. (2021). Understanding propaganda: A conversation with Renee Hobbs. *Phi Delta Kappan*, 102(5), 33-37. <https://doi.org/10.1177/0031721721992563>
- Hobbs, R. (2010). *Digital and media literacy: A plan of action*. Washington, DC: The Aspen Institute.
- Hobbs, R. (2017). Measuring the digital and media literacy competencies of children and teens. In F. C. Blumberg & P. J. Brooks (Eds.), *Cognitive development in digital contexts* (pp. 253-274). Academic Press.
- Hodgin, E. (2019). Participatory politics and the civic dimensions of media literacy. In R. Hobbs & P. Mihailidis (Eds.), *The international encyclopedia of media literacy* (pp. 1-11). Wiley. <https://doi.org/10.1002/9781118978238.ieml0179>
- Hoyle, R. H. (1995). *Structural equation modeling: Concepts, issues, and applications*. Sage Publications, Inc.
- Jenkins, H. (2016). Youth voice, media, and political engagement: Introducing the core concepts. In H. Jenkins, S. Shresthova, L. Gamber-Thompson, N. Kligler-Vilenchik, & A. Zimmerman (Eds.), *By any media necessary: The new youth activism* (pp. 1-60). New York: New York University Press.
- Kahne, J., Lee, N.-J., & Feezell, J. T. (2012). Digital media literacy education and online civic and political participation. *International Journal of Communication*, 6(1), 1-24.
- Kahne, J., & Bowyer, B. (2019). Can media literacy education increase digital engagement in politics? *Learning, Media and Technology*, 44(2), 211-224. <https://doi.org/gg238b>
- Kaid, L. L., McKinney, M. S., & Tedesco, J. C. (2007). Introduction: Political information efficacy and young voters. *American Behavioral Scientist*, 50(9), 1093-1111. <https://doi.org/10.1177/0002764207300040>



- Keller, T. R., & Kleinen-von Königslöw, K. (2018). Followers, spread the message! Predicting the success of Swiss politicians on Facebook and Twitter. *Social Media + Society*, 4(1). <https://doi.org/10.1177/2056305118765733>
- Kim, D., & Johnson, T. J. (2012). Political blog readers: Predictors of motivations for accessing political blogs. *Telematics and Informatics*, 29(1), 99–109. <https://doi.org/b8z78g>
- Kim, E. H. (2019). Critical methodology of media literacy: A Kantian analysis. *Journal of Dharma*, 44(2), 155–176.
- Kiyohara, S., Maeshima, K., & Owen, D. (2018). *Internet election campaigns in the United States, Japan, South Korea, and Taiwan*. Cham, Switzerland: Springer Palgrave.
- Koc, M., & Barut, E. (2016). Development and validation of New Media Literacy Scale (NMLS) for university students. *Computers in Human Behavior*, 63, 834–843. <https://doi.org/10.1016/j.chb.2016.06.035>
- Koo, C., Chung, N., & Kim, D. J. (2014). How do social media transform politics? The role of a podcast, “Naneun Ggomsuda” in South Korea. *Information Development*, 31(5), 1–14. <https://doi.org/10.1177/0266666913516883>
- Lailiyah, N., Yuliyanto, M., & Pradhana, G. A. (2018). Youthizen, political literacy, and social media. *E3S Web of Conferences*, 73, 14005.
- Lee, A. Y. L., & Ting, K. W. (2015). Media and information praxis of young activists in the Umbrella Movement. *Chinese Journal of Communication*, 8(4), 376–392. <https://doi.org/10.1080/17544750.2015.1086399>
- Lewis, J., & Jhally, S. (1998). The struggle over media literacy. *Journal of Communication*, 48(1), 109–120. <https://doi.org/10.1111/j.1460-2466.1998.tb02741.x>
- Lin, T., Li, J., Deng, F., & Lee, L. (2013). Understanding new media literacy: An explorative theoretical framework. *Educational Technology & Society*, 16(4), 160–170.
- Loader, B. D., Vromen, A., & Xenos, M. (Eds.) (2014). *The networked young citizen: Social media, political participation and civic engagement* (1st ed.). Routledge.
- Martens, H., & Hobbs, R. (2015). How media literacy supports civic engagement in a digital age. *Atlantic Journal of Communication*, 23(2), 120–137. <https://doi.org/gp6b46>
- Marttila, E., Koivula, A., & Räsänen, P. (2021). Cybercrime victimization and problematic social media use: Findings from a nationally representative panel study. *American Journal of Criminal Justice*, 46(6), 862–881.
- Middaugh, E. (2018). Civic media literacy in a transmedia world: Balancing personal experience, factual accuracy and emotional appeal as media consumers and circulators. *Journal of Media Literacy Education*, 10(2), 33–52.
- Middaugh, E. (2019). More than just facts: Promoting civic media literacy in the era of outrage. *Peabody Journal of Education*, 94(1), 17–31. <https://doi.org/jrcr>
- Mihailidis, P. (2019). Civic media literacies. In R. Hobbs & P. Mihailidis (Eds.), *The International Encyclopedia of Media Literacy* (pp. 1–10). Wiley.
- Mohamad, B., Dauda, S. A., & Halim, H. (2018). Youth offline political participation: Trends and role of social media. *Jurnal Komunikasi: Malaysian Journal of Communication*, 34(3), 192–207. <https://doi.org/jrcs>
- Mohd Sufiean Hassan, Maizatul Haizan Mahbob, & Siti Nurshahidah Sah Allam. (2020). Analisis psikometrik literasi media baharu dan pemantapan integriti penyertaan politik golongan muda. *Jurnal Komunikasi: Malaysian Journal of Communication*, 36(2), 143–166.

- Mohd Sufiean Hassan, Siti Nurshahidah Sah Allam, Muhamad Hanapi Khamis, Mohd Hilmi Bakar, Dzaa Imma Abdul Latiff, & Abdul Rauf Ridzuan. (2019). Perspektif literasi media aspek analisis dan penilaian: Amalan integriti penyertaan politik golongan muda di media sosial. *Jurnal Sains Sosial*, 4(1), 20-32.
- Nunnally, J. C., & Bernstein, I. H. (1994). *Psychometric theory* (3rd ed.). McGraw-Hill.
- Nupairoj, N. (2016). The ecosystem of media literacy: A holistic approach to media education. *Comunicar*, 24(49), 29–37. <https://doi.org/10.3916/C49-2016-03>
- Omotayo, F. O., & Folorunso, M. B. (2020). Use of social media for political participation by youths in Oyo State, Nigeria. *eJournal of eDemocracy and Open Government*, 12(1), 132–157. <https://doi.org/10.29379/jedem.v12i1.585>
- Ojebuyi, B. R., & Salawu, A. (2015). Media literacy, access and political participation among South African Black Youth: A study of North-West University, Mafikeng Campus. *Journal of Communication*, 6(1), 207–218.
- Östman, J. (2012). Information, expression, participation: How involvement in user-generated content relates to democratic engagement among young people. *New Media and Society*, 14(6), 1004–1021. <https://doi.org/10.1177/1461444812438212>
- Potter, W. J. (2018). *Media literacy*. Sage Publications.
- Powers, E., Moeller, S., & Yuan, Y. (2016). Political engagement during a presidential election year: A case study of media literacy students. *Journal of Media Literacy Education*, 8(1), 1–13.
- Ptaszek, G. (2018). Measurement of media literacy outcomes. *The International Encyclopedia of Media Literacy*, 1(1), 1–15.
- Samuel-Azran, T., Yarchi, M., & Wolfsfeld, G. (2017). Engagement and likeability of negative messages on Facebook during Israel's 2013 elections. *The Journal of Social Media in Society*, 6(1), 42-68.
- Scherman, A., & Rivera, S. (2021). Social media use and pathways to protest participation: Evidence from the 2019 Chilean social outburst. *Social Media+ Society*, 7(4), 20563051211059704.
- Shiratuddin, N., Sani, M. A. M., Hassan, S., Ahmad, M. K., Talib, K. A., & Ahmad, N. S. Y. (2016). Generation Y's political participation and social media in Malaysia. *Jurnal Komunikasi: Malaysian Journal of Communication*, 32(1), 246-262.
- Silverblatt, A. (2018). Media literacy and critical thinking. *International Journal of Media and Information Literacy*, 3(2), 66–71.
- Siti Nurshahidah Sah Allam, Mohd Sufiean Hassan, Abdul Mutalib Mohamed Azim, Anisafina Maidin, & Siti Najah Raihan Sakrani. (2020). Media literacy dimension in reinforcing political participation integrity among young people in social media. *International Journal of Academic Research in Business and Social Sciences*, 10(3), 309–329. <http://dx.doi.org/10.6007/IJARBS/v10-i3/7053>
- Shaari, A. H., & Kamaluddin, M. R. (2019). Buli siber: Ketidaksantunan bahasa dan etika media sosial dalam kalangan remaja Malaysia. *e-BANGI*, 16, 1-16.
- Sushama, C., Kumar, M. S., & Neelima, P. (2021). Privacy and security issues in the future: A social media (Withdrawn paper). *Materials Today: Proceedings*. <https://doi.org/jrcw>
- Suwana, F. (2021). Content, changers, community and collaboration: Expanding digital media literacy initiatives. *Media Practice and Education*, 22(2), 153-170.
- Syahputra, I. (2019). Expressions of hatred and the formation of spiral of anxiety on social media in Indonesia. *SEARCH*, 11(1), 95–112.

- Taib, R., & Yaakop, M. R. (2017). Political participation: Radical young people in Malaysia. *International Journal of Academic Research in Business and Social Sciences*, 7(6), 925-939.
- Tugtekin, E. B., & Koc, M. (2020). Understanding the relationship between new media literacy, communication skills, and democratic tendency: Model development and testing. *New Media and Society*, 22(10), 1922–1941. <https://doi.org/gndjvn>
- van Deursen, A., & van Dijk, J. (2008). *Measuring digital skills: Performance tests of operational, formal, information and strategic Internet skills among the Dutch population* (Conference paper). Paper Presented at the 58th Conference of the International Communication Association.
- Vraga, E. K., & Tully, M. (2019). News literacy, social media behaviors, and skepticism toward information on social media. *Information, Communication & Society*, 24(2), 150–166. <https://doi.org/10.1080/1369118X.2019.1637445>
- Wallis, R., & Buckingham, D. (2016). Media literacy: The UK's undead cultural policy. *International Journal of Cultural Policy*, 25(2), 188-203. <https://doi.org/gm3dhw>
- Weeks, B. E., Ardèvol-Abreu, A., & Gil de Zúñiga, H. (2017). Online influence? Social media use, opinion leadership, and political persuasion. *International Journal of Public Opinion Research*, 29(2), 214-239.
- Willnat, L., Wong, W. J., Tamam, E., & Aw, A. (2013). Online media and political participation: The case of Malaysia. *Mass Communication and Society*, 16(4), 557–585. <https://doi.org/10.1080/15205436.2012.734891>
- Zoizner, A. (2021). The consequences of strategic news coverage for democracy: A meta-analysis. *Communication Research*, 48(1), 3–25. <https://doi.org/gpkqjg>